



INTRODUCTION

The Seattle LightFoot² with Titanium Pyramid is approved for use by all lower extremity amputees with low to medium activity levels. Its Delrin keel provides rollover assistance and stability. The Seattle LightFoot² with Titanium Pyramid is available in two heel rises (3/4" and 3/8") and three color options.

Product Code	Description	Heel Rise	Patient Weight
SLF190	Caucasian	3/4"	136 kg / 300 lb (Med. Activity)
SLF191	Light Brown	3/4"	136 kg / 300 lb (Med. Activity)
SLF193	Dark Brown	3/4"	136 kg / 300 lb (Med. Activity)
SLF195	Caucasian	3/8"	136 kg / 300 lb (Med. Activity)
SLF196	Light Brown	3/8"	136 kg / 300 lb (Med. Activity)
SLF198	Dark Brown	3/8"	136 kg / 300 lb (Med. Activity)

LIMITATIONS

The Seattle LightFoot² with Titanium Pyramid cannot be used with R.O.L rotators or other devices that require modification of the keel.

INSTALLATION AND USE

Recommended installation and use procedures must be followed for maximum safety and service life.

The Seattle LightFoot² with Titanium Pyramid comes pre-assembled with a Trulife spacer, foot pyramid and foot bolt. Before installation, check the bolt for loosening, ensuring that the bolt is set to a torque value of 27 Nm (20 ft-lbs or 240 in-lbs).

Warning: Never modify the keel. It will void the warranty and can cause bolt or keel failure. If you must alter the form of the foot, be sure not to grind on the keel.

Warning: Never re-drill the mounting hole.

Warning: Never modify the spacer. It will void the warranty and may cause failure.

Warning: Use only bolts supplied by Trulife. Use of unapproved bolts will void the warranty and can cause bolt failure.

Endoskeletal Installations

When using the Seattle LightFoot² with Titanium Pyramid with a Seattle Endoskeletal Cosmesis, remove the foot from the endoskeletal limb. Completely rough the mounting surface of the foot and cosmesis. Remove all foam particles from the abraded surfaces. If desired, apply small reference marks to the mounting surfaces to facilitate careful matching of the surfaces. Apply a thin layer of contact cement to each surface and allow it to dry. Apply a second layer of contact cement and allow to dry. Match the two surfaces carefully and press them together tightly both on the outside and inside of the seam.

Color Coating

Before applying color coating to the foot, remove any remaining mold release from the cosmesis with naphtha. Naphtha is recommended to improve the adhesion of color coating, but alcohol can be used as well.

ALIGNMENT

The recommendations in this guide provide reliable starting points for static alignment of the Seattle LightFoot² with Titanium Pyramid. Since each patient is unique, final alignment may require additional adjustment.





Bolt Hole Alignment

To establish anterior/posterior placement of the foot, place the ankle bolt hole 13-25 mm (1/2"-1") posterior to the midline of the socket. To establish medial/lateral placement of the foot, position the ankle bolt hole in line with the midline of the proximal socket.

Above Knee Alignment

Use standard foot alignment procedures when installing the Seattle LightFoot² with Titanium Pyramid,

MAINTENANCE GUIDELINES

- Foot assembly should be inspected after first 30 days of use.
- Inspect entire prosthesis for wear during normal consultations.
- Periodically check the bolt for loosening. Retorque to 27Nm (20 ft-lbs or 240 in-lbs) if loose.

Warning: Looseness of foot bolt may lead to bolt failure.

QUESTIONS

Contact Customer Service in the U.S. at 888-878-1238, or fax 888-878-1237
If calling from outside the U.S., contact Customer Service at 360-697-5656,
or fax 360-697-6843. Visit Trulife online at www.trulife.com

LIMITED WARRANTY

Trulife warrants that the Seattle LightFoot² with Titanium Pyramid will be free from defects in material and workmanship for two (2) years from the date of installation.

This warranty will not apply if the product has been damaged by misuse, abuse, neglect, improper care, failure to follow instructions, abnormal wear and tear, or in the event that the Seattle LightFoot² with Titanium Pyramid has been modified/ repaired by persons unauthorized by Trulife.

If a defect in material or workmanship is found during the warranty period, Trulife will, at Trulife's option, either repair or replace the product. If it is not possible to repair or replace the product, Trulife will be limited to refunding the purchase price.

Trulife will not be liable under any legal theory for any direct, indirect, special, incidental or consequential damages arising from the use of or inability to use this product.

The application guidelines for this Trulife product are for the use of and by certified, qualified practitioner only. Patients are not to attempt to apply or adjust the item unless expressly instructed to do so by the practitioner responsible for the prescription and/or initial fitting of the device. All patient questions should be referred to the practitioner and not to the manufacturer. The manufacturer warrants only that the enclosed product has been inspected for quality and can be effective for certain indications, but final decisions and ongoing monitoring must be made by the prosthetic professional(s) prescribing and/or fitting the device to determine its effectiveness for an individual patient. Patient compliance is an integral part of the entire protocol and must be adhered to in order to avoid potential problems and to maximize the effectiveness of the prescribed product.

As a condition of the sale of any Trulife product, this prosthesis is restricted to a "Single Patient Use Only" by the originally fitted patient in order to protect the care provider and the patient against potentially adverse consequences of infectious disease transmission, material instability in adapting to the configuration of the original user and/or decrease in effectivity. Any express or implied warranties are voided if the product is reused or fitted to another patient. Additionally, a license of right to use under any relevant patents pertaining to the product is terminated with the cessation of use by the original patient. As with all Trulife products, this product must be prescribed and applied by a qualified practitioner to determine it meets the needs of the particular patient and accomplishes the desired results.

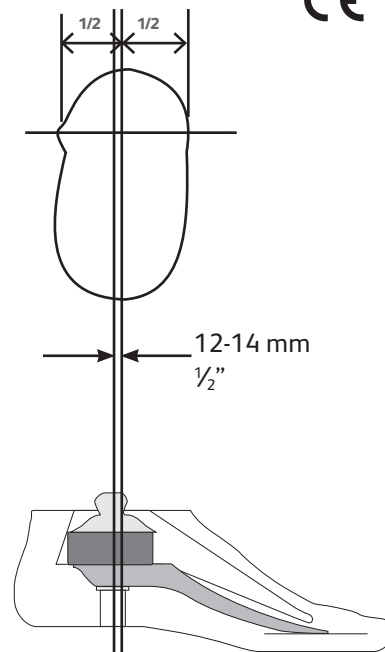

FIGURE 1. Alignment.

