

DynAdapt™ Instructions for Use

Product Number: F10



Assembly

The DynAdapt foot module comes pre-assembled consisting of a composite foot module, Spectra™ sock, and foot shell. Heel stiffening bumpers for increasing heel stiffness if desired are also provided. After dynamic alignment, torque pyramid adjustment screws to the manufacturer's specifications.

Bench Alignment

Sagittal Plane:

- Introduce the appropriate socket flexion and heel height, according to the amputee's requirements.
- Position the weight line, taken from the center of the socket at the patellar tendon level, so that it falls along the anterior edge of the pylon.

Coronal Plane:

- Introduce the appropriate socket adduction/abduction, according to the amputee's requirements.
- Position the weight line, taken from the center of the socket at the patellar tendon level, so that it falls through the midline of the foot module in a neutral M-L position.

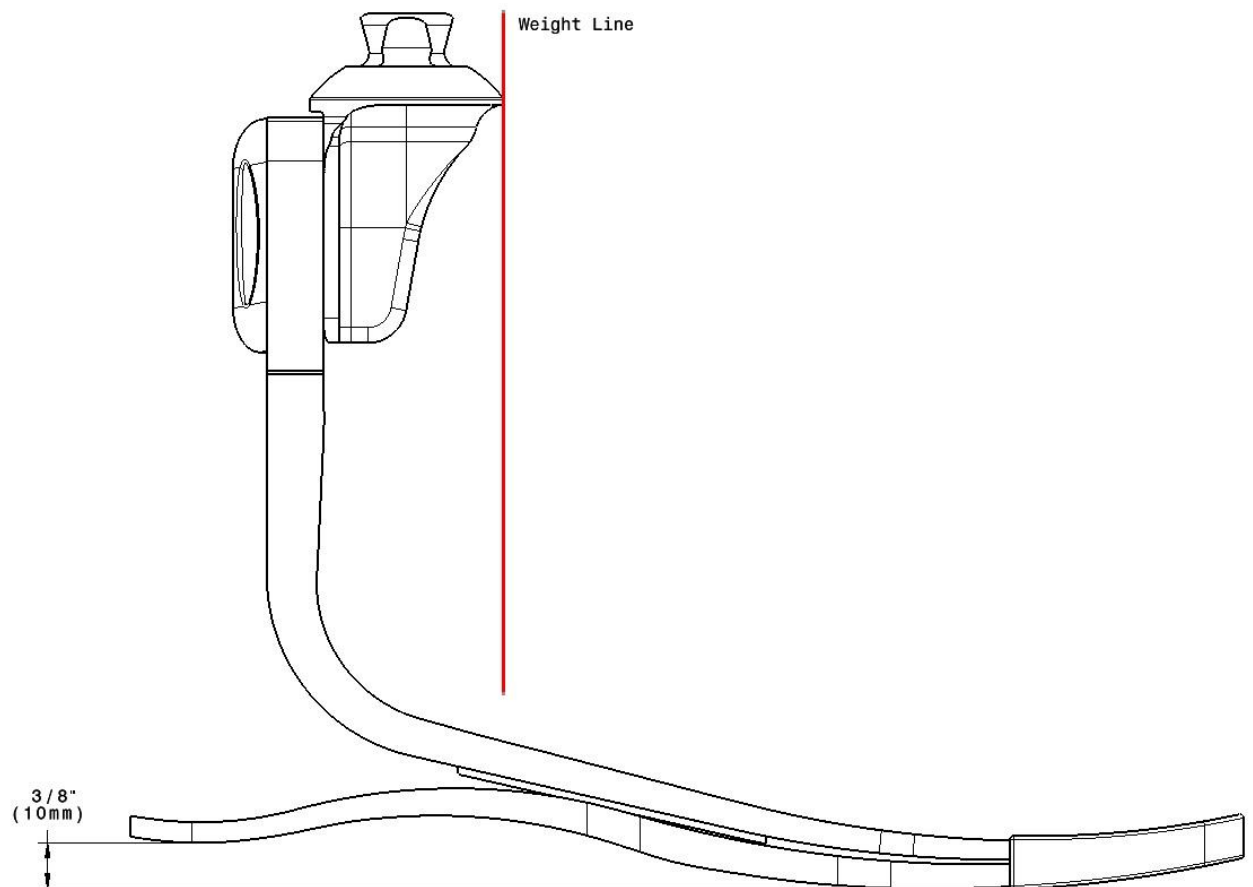

Static Alignment

Follow the following steps:

- Fit the anatomical foot cover onto the foot module (if removed) and place into shoe. Use heel wedges to ensure that the weight line falls along the anterior edge of the pylon.
- Establish the correct height of the prosthesis by having the amputee stand with feet approximately 4" apart, and equal weight bilaterally.
- Check socket flexion, load line position and toe-out. Correct as necessary.

Dynamic Alignment

During *loading response*, the heel lever stores energy and releases it during *midstance*. This action provides momentum for the keel to store energy and release it during *terminal stance*. To optimize the heel to toe rollover motion, adjust the following variables:

- Anterior/posterior foot placement
- Dorsiflexion/plantarflexion
- Heel stiffness.

Use Loctite 242 (not provided), and torque pyramid adjustment screws to the manufacturer's recommendations. All screws should be re-torqued after dynamic alignment of the prosthesis.

Troubleshooting

Heel too soft

Symptoms

- User feels they are walking uphill
- Toe feels excessively stiff
- Knee hyperextension

Solutions

- Shift socket anteriorly in relation to the foot
- Attach heel stiffening bumper as detailed below

Heel too hard

Symptoms

- Rapid knee flexion, instability
- Heel to toe progression too rapid
- Lack of energy return sensation

Solutions

- Shift socket posteriorly in relation to the foot
- Verify appropriate foot module category

Foot module too stiff or soft

Symptoms

- Flat spot in rollover motion at slow cadences
- Excessive stiffness
- Excessive deflection

Solutions

- Consider a lower or higher category foot module

If the proposed solutions do not result in a satisfactory outcome, please contact Freedom Innovations Technical Services for further support. (888)818-6777 or (949)672-0032

Stiffening Bumper

Rubber *stiffening bumpers* are included to adjust the heel stiffness during *loading response*. The bumpers may be temporarily attached between the heel lever and the keel using the pre-applied adhesive in the location indicated on the bumper package to increase heel stiffness one category. If the heel stiffness is too stiff, move the bumper posteriorly; still too soft, move it anteriorly. For permanent placement, clean off the pre-applied adhesive with Acetone, and adhere bumpers using Super Glue (cyanoacrylate).

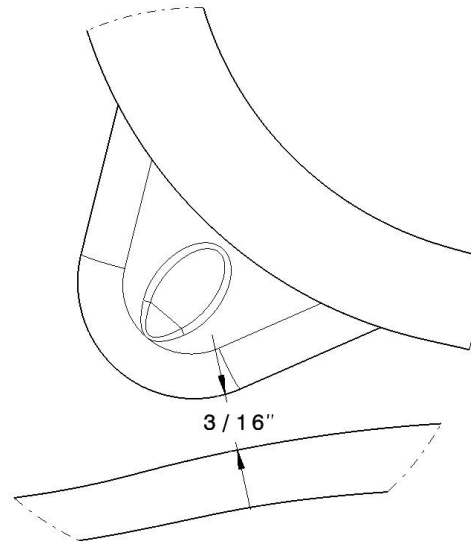

If the bumper provides excessive heel stiffness, move bumper further up the keel (increase gap) until desired stiffness is achieved. If the bumper does not provide enough heel stiffness, move bumper further down the keel (decrease gap) until desired stiffness is achieved. For permanent placement, adhere bumpers using cyanoacrylate (Super Glue). After permanent placement, cut tab between bumpers out using a razor blade.

Spectra™ Sock

A Spectra™ sock is provided to minimize noise and protect the foot shell and composite components. The Spectra™ sock should be placed over the foot module before donning the footshell. Spectra™ socks must be replaced at intervals appropriate to the user's activity level. Failure to inspect and replace the Spectra™ socks may prematurely wear the foot module, and will void the warranty.

Foot Shell

When removing or installing the footshell, use the Footshell Removal Tool (ACC-00-10200-00) to prevent damage to the foot module.

DynAdapt™ Foot

| | |
|----------------------|--|
| Minimum clearance: | 158mm-182mm |
| Maximum user weight: | 166 kg (365 lbs) |
| Available sizes: | 22cm-31cm |
| Warranty: | Foot module (36 months) Foot shell (6 months) |

Maintenance

The foot module requires periodic maintenance.

- Inspect the foot system every six months. If the user is more active, more frequent inspection may be necessary. Service as necessary. Replace Spectra™ sock and/or foot shell if worn to prevent damage to the foot module.
- The foot system may be cleaned and/or disinfected with soap and warm water.
- Do not allow aggregates such as sand to remain in the foot shell. Upon exposure to aggregates, immediately disassemble foot module and rinse with water. The abrasive properties of aggregates will quickly wear the composite components of the foot module.

Warnings

Failure to adhere to the guidelines of the *Instructions for Use* will void the warranty.

- Never use the foot module without a foot shell.
- Never assemble the DynAdapt™ foot module without a Spectra™ sock. This will lead to premature failure of the foot module, and will *void the warranty*.
- Freedom Innovations foot modules are manufactured to fit industry standard pyramids and receivers. It is the Prosthetist's responsibility to select and/or fabricate properly fitting attachment components.
- Never attempt to loosen the bolts affixing the pyramid connector.
- Discontinue use and consult your prosthetist if any part of the prosthesis starts to make noise.
- Inform your prosthetist if you lose or gain a significant amount of weight.
- Freedom Innovations foot products are manufactured and tested for a particular weight and activity impact level. Use by another user for whom it was not originally manufactured may cause injury and shall void any written or implied warranty.



Jaargetijdenweg 4
7532 SX Enschede
The Netherlands
tel +31 (0)53-20 30 300
fax +31 (0)53-20 30 305
info@freedom-innovations.eu



Advena Ltd. Pure Offices, Plato
Close, Warwick, CV34 6WE UK